



**SECURITY
DEVICES**

**OMNILOCK[®]
ACCESS CONTROL SYSTEMS**

INSTALLATION INSTRUCTIONS FOR OM2000 SERIES NON-WEATHERIZED CYLINDRICAL LOCKSET USING SCHLAGE[®] D-SERIES LOCKS (LEVER)

WARNING: THIS PRODUCT IS NOT WARRANTED FOR OUTDOOR USE!
NOTE: A DOOR-CLOSER IS HIGHLY RECOMMENDED FOR USE WITH THIS PRODUCT.

THIS PRODUCT IS NORMALLY FACTORY-PACKED FOR RIGHT-HAND 1-3/4" THICK DOORS.
TO CHANGE HAND OF LOCK, SEE INSTRUCTION SECTION 3
DO NOT USE ON 2" THICK DOORS.

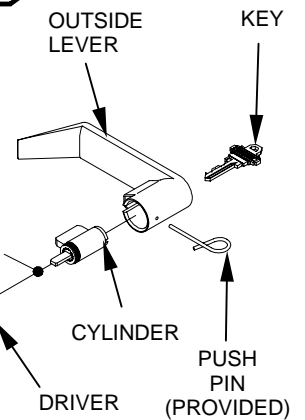
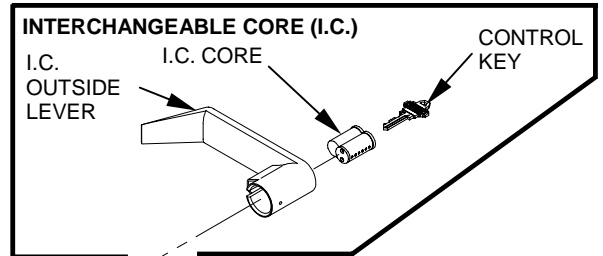
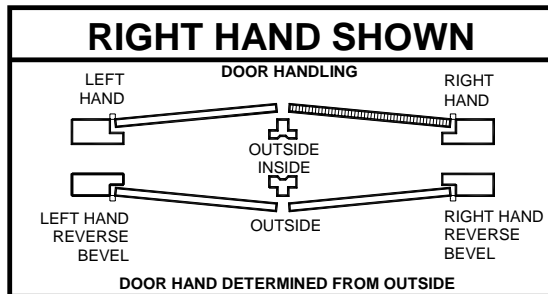

AA ALKALINE BATTERY, 1.5V (4 REQ'D)

CASTLE NUT

MOTOR CONNECTOR

KEY DETECTION CONNECTOR (OPTIONAL)

CPU PC BOARD ASSEMBLY

2 YELLOW WIRES NO POLARITY (OPTIONAL)

TERMINAL BLOCK (FOR REMOTE SWITCH)

RESET BUTTON

BLACK WIRE

RED WIRE

MOTOR CONNECTOR

KEY DETECTION CONNECTOR

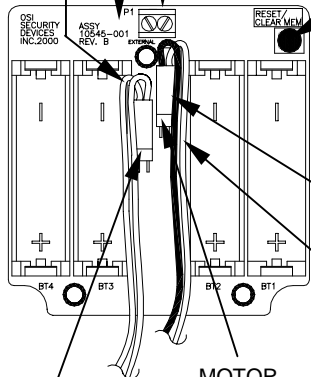

RESET BUTTON

BLACK WIRE

RED WIRE

MOTOR CONNECTOR

KEY DETECTION CONNECTOR

ROSE

OUTSIDE SPRING CAGE

(THREADED POST)

LOCK BODY

SPINDLE

INSIDE, SPRING CAGE

CASTLE NUT

ROSE

DRIVER

INSIDE LEVER

SCREW, FLAT HEAD, #8-32 X 2-1/8" (2 REQ'D)

SCREW, FLAT HEAD, #12 X 3/4" (2 REQ'D)

HOUSING ASSEMBLY (KEYPAD VERSION SHOWN)

COVER

SEMS #4-40 X 1/4" PAN HEAD

GASKET

BACK PLATE

FLAT HEAD MACHINE SCREW #8-32 X 3/8" LG (4 REQ'D)

LATCH UNIT

STRIKE

SCREW FLAT HEAD #8 X 3/4" (2 REQ'D)

SCREW FLAT HEAD #12 X 3/4" (2 REQ'D)

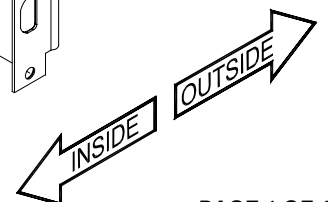

SECTION 1: INSTALL THE OUTSIDE LEVER, KEY CYLINDER & DRIVER

1-1 IF THE LEVER REQUIRES A STANDARD KEY CYLINDER, PROCEED AS FOLLOWS, OTHERWISE GO TO STEP 1-2:

- Place the Cylinder inside the Outside Lever. Engage the Key of the Driver with the Keyway in the Lever.
- Partially insert the Key into the Cylinder and slide the Lever/Driver Assembly onto the Spindle until it stops against the Lever Catch.
- Insert the Key fully and turn it 45° clockwise. Push the Lever into place until the Lever Catch is engaged. Pull on the Lever to make sure the Lever Catch is engaged. Turn the Key back to the normal position and remove it from the Cylinder.

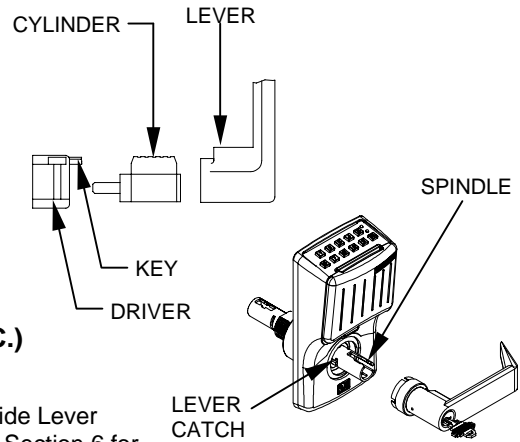

1-2 IF THE LEVER REQUIRES AN INTERCHANGEABLE CORE (I.C.) PROCEED AS FOLLOWS:

Engage the Key of the Driver with the Keyway in the Lever. Press the I.C. Outside Lever Driver Assembly onto the Spindle until the Lever Catch is engaged and refer to Section 6 for IC Core installation.

SECTION 2: CHECK OPERATION

- If your System has a Magnetic Card Reader, verify proper operation of the System using the Magnetic Card Reader otherwise go to Step b. A Label on the Housing Assembly Cover indicates the magnetic card track, Track 2 or Track 3, that the System is set to read. Insert and remove the applicable Default Programmer ID Card (Supplied with the Administrator's Kit). The magnetic stripe on the card should be aligned with the " V " mark by the card slot. The OM2000 will flash green once and unlock, then, during the Open Delay Time, it will flash green five times. The OM2000 will then flash red and lock. While unlocked, check for proper operation of the Lock.
- If your System has a Keypad Proceed as follows, otherwise go to Step c: Verify proper operation of the System using the Keypad. Enter the Default Programmer ID, **1 2 3 4**, at the Keypad. The Lights will flash as in the previous step.
- If Key Detection is installed, proceed as follows, otherwise go to step d: verify proper operation of the Key Detection Indicator by inserting the Key into the Key Cylinder and rotating clockwise. The green light will flash.
- If the System malfunctions remove the Battery Cover and check for proper orientation and seating of the Batteries, Motor Connector and if installed, the Key Detection Connector. Ensure that the wires are not pinched. Reset the electronics by pressing and holding the Reset Button on the circuit board until the light flashes green, approximately three seconds. The System will go through a self-test and flash green 5 times. Any red flash indicates an electronics or motor problem. Repeat the verification process if all flashes are green.

SECTION 3: ADJUST THE LOCK HAND

3-1 DISASSEMBLE THE HOUSING ASSEMBLY

This section is only required if the lock hand does not meet your requirements. The Lockset is normally preset for a right hand door. Verify the hand of the Lock and, if required, change the hand of the Lock as follows after checking per Section 2.

- Carefully release the Gasket from the edge of the Housing Assembly using your fingers, and remove the Gasket. Remove the Screw from the Battery Cover and remove the Cover. Disconnect the Motor Connector and Key Detection connector, if Key Detection is installed, from the CPU Board.
- Remove four Flat Head Screws from the Back Plate and remove the Back Plate.

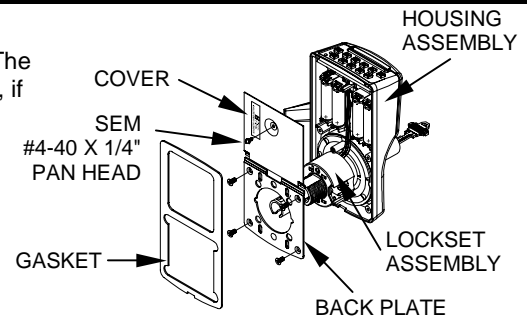

3-2 ADJUST THE LOCK HAND

- Rotate the lockset to left-hand orientation.
- Route the Wires close to the center of the Lockset and to the upper center of the Outside Rose.
- Install the Back Plate and four Screws into the Housing Assembly.

WARNING: Ensure that the Wires are not pinched before and after tightening the Screws.

- Install the Motor Connector with the Black Wire to the left (see label on CPU Board) and install the Key Detection connector, if Key Detection is installed. Arrange the excess wire between the Battery Holders.
- Install the Battery Cover and secure it with the Screw.
- Install the Gasket so that it seats inside the edge of the Housing.
- Repeat Section 2.

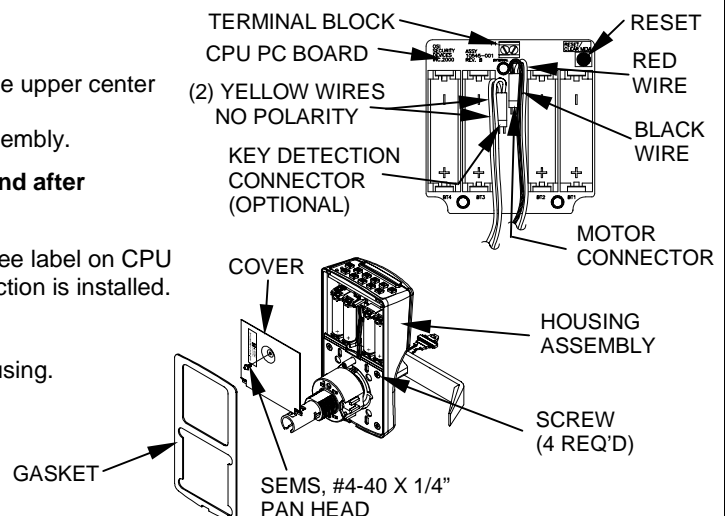

SECTION 4: PREPARE THE DOOR

4-1 MARK HOLE LOCATIONS

- Mark a height line on the door faces and edge (suggested height is 38" from the floor).
- Line up the Template at the correct marking for the Door Bevel (high or low bevel, or flat). Position the centerline of the Template on the height line. Note whether the holes should be marked on the inside, outside, or both sides of the door. Mark the Centers as required for the holes.
- Mark the center of the Door thickness on the height line.

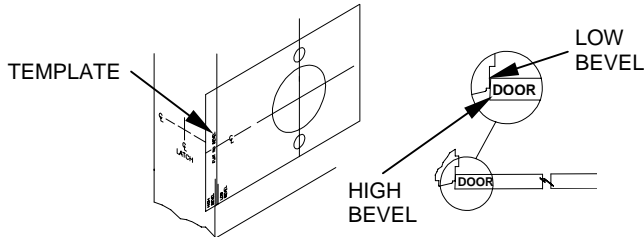

4-2 DRILL HOLES

- Bore the 2-1/8" hole and the 5/16" holes half way through the door from both sides to avoid splintering.
- Bore a 1" hole into the door edge center on the height line. Use the Latch Unit Faceplate as a pattern and mark the door edge. Mortise the door edge so that the front of the Faceplate will be flush with the door edge. Insert the Latch Unit into the 1" hole, making certain that the Latch Bolt Bevel faces the direction of the closing Door.
- Secure the Latch Unit with the Screws supplied.

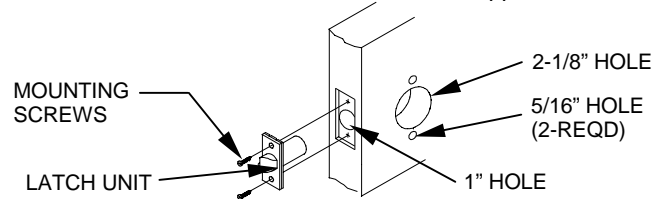

SECTION 5: INSTALL THE SYSTEM ON THE DOOR

5-1 VERIFY THE DOOR THICKNESS SETTING

NOTE: DO NOT INSTALL ON A DOOR THICKER THAN 1-3/4" UNLESS THE SYSTEM IS SPECIFICALLY DESIGNED FOR A THICKER DOOR.

- The Lock is normally preset for a 1-3/4" Door. For a 1-3/4" Door the "1-3/4" DR marking" on the Template is aligned with the edge of the Slide Housing.
- If the setting requires adjustment, remove the Outside Lever per Section 9 and proceed as follows, otherwise go to Section 5-2.
- Place the Template against the Gasket and locate the marking for the Door thickness.
- Use the Installation Tool to rotate the Castle Nut until the Slide Housing is aligned with the Template.

NOTE: For Push Plates, turn the Castle Nut counter clockwise until the edge of the Slide Housing is the thickness of the Push Plate beyond the door thickness marking on the Template.

- Re-install the Outside Lever per Section 1.

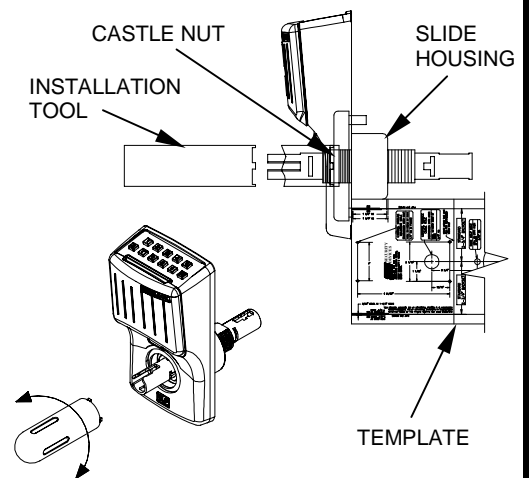

5-2 INSTALL THE HOUSING ASSEMBLY

Install the Lock on the outside of the door. The Slide Housing must engage the Latch Unit Prongs as shown. The Lock Body Retractor must engage the Latch Unit Tail Piece.

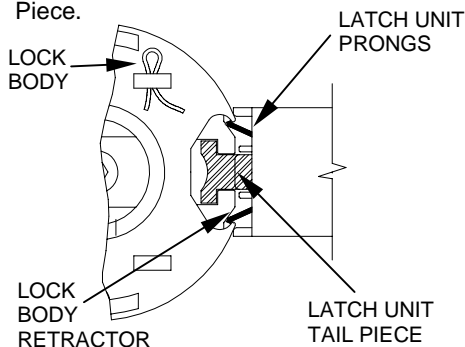

5-3 SECURE THE HOUSING ASSEMBLY TO THE DOOR

- Hold the Lock in place.
- Put the Spring Cage into position on the Chassis.
- Start the Castle Nut on the threads of the Chassis. Ensure that the Housing Assembly is parallel to the edge of the door and while holding the Unit in position, place the Installation Tool onto the Castle Nut and tighten until the Castle Nut is tight against the Spring Cage.
- Insert and tighten the Mounting Screws.
- Re-tighten the Castle Nut.
- Install the Inside Rose. Align the dimples on the Rose with the grooves in the Spring Cage. Place the Rose against the Door and rotate clockwise until the dimples snap into the slots next to the grooves.

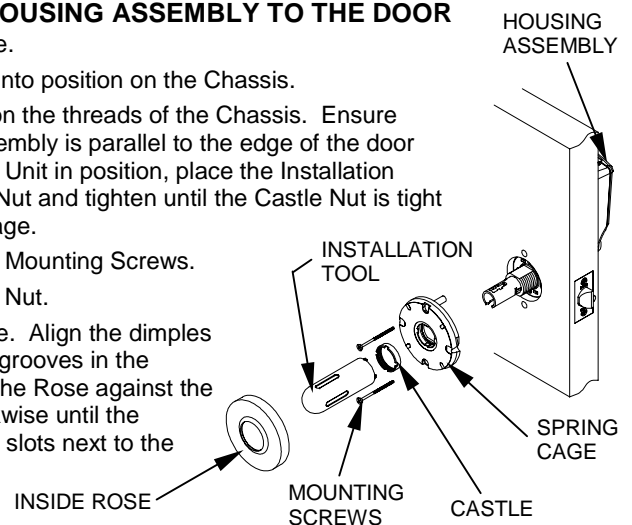

5-4 INSTALL THE INSIDE LEVER AND DRIVER

- Engage the key of the Driver with the Keyway in the Lever.
- Slide the Lever and the Driver onto the Spindle. Push the Lever completely into place. Pull on the Lever to make sure that the Lever Catch is fully engaged.
- Repeat Section 2 to verify proper operation.

CAUTION: Binding or rough operation is an indication of improper installation.

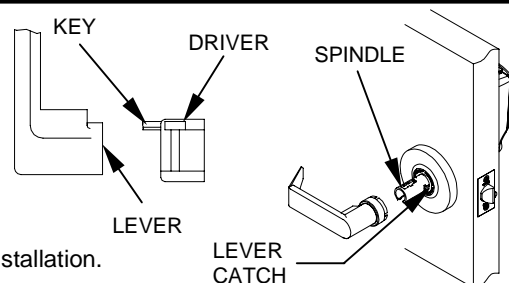

SECTION 6: INTERCHANGEABLE CORE

INTERCHANGEABLE CORE (I.C.) INSTALLATION

Insert the control Key into the Core and rotate it 15° clockwise. Insert the Core into the I.C. Outside the Lever and turn the Control Key 15° counterclockwise to lock the Core in the Lever. Remove the Control Key.

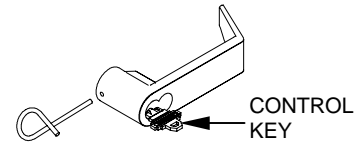

SECTION 7: INSTALL THE STRIKE

- Mark a height line and a vertical line on the Door Frame opposite the Latch hole in the Door.
- Center the Strike over the Latch Bolt Mark and, using the Strike as a template, mark the Frame.
- Mortise the Frame to accept the Strike.
- Install the Strike and secure with the Screws.

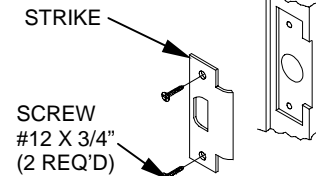

SECTION 8: PROGRAM THE SYSTEM

IMPORTANT: To avoid unauthorized access, it is important to program a new Programmer ID.

Refer to the OMNILOCK Administrator's Guide for programming instructions. If the System has been installed on a door before the required programming information is available, and your system has a keypad, the access Level may be set to Unlocked as follows:

- Enter the Default Manager ID **2 2 2 2**, at the keypad, the green light will flash.
- Press **2**, the green light will flash.
- Press and hold the **CL** key until the green light flashes four times. (The light will flash once when the **CL** key is pressed, continue to hold the key until the light flashes three more times.)
- The System will remain in the Unlocked mode.

SECTION 9: REMOVAL OF LEVER

9-1 REMOVING OUTSIDE LEVER WITH STANDARD CYLINDER

- Insert the Key into the Cylinder and turn 45° clockwise.
- Depress the Lever Catch through the hole in the Outside Lever by using the Push Pin provided or another suitable tool.
- Slide the Outside Lever from the Spindle.

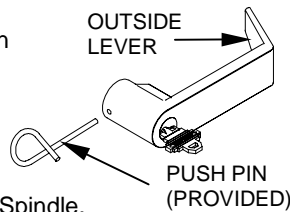

9-2 REMOVING OUTSIDE LEVER WITH INTERCHANGEABLE CORE (I.C.)

- Insert the Operating Key into the Core and rotate it 45° clockwise.
- Depress the Lever Catch through the hole in the Lever by using the Push Pin provided or another suitable tool.
- Slide the Lever from the Spindle.

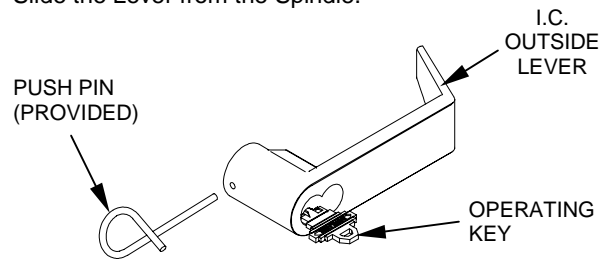

9-3 REMOVING THE INSIDE LEVER

- Depress the Lever Catch through the hole in the Inside Lever by using the Push Pin provided or another suitable tool.
- Slide the Inside Lever from the Spindle.

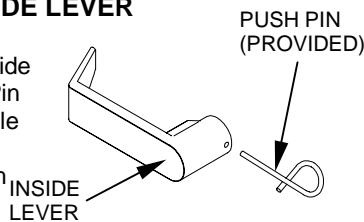

SECTION 10: REMOTE SWITCH

- Remote operation of the System may be accomplished by a momentary Switch closure. This may be desirable for someone monitoring a protected entrance, such as a receptionist. Momentarily pressing the Switch will cause the System to go through a normal unlock and lock sequence. If the Switch is held closed, the open time will be extended.
- Connect a **twisted pair** of wires from the Terminal Block on the PC Board to a normally open momentary contact Switch. Plan the route for your wire and the access route through the door to the PC Board in the OMNILOCK Module. Plan for disconnecting the wires in the Lock area so that the System can be removed from the door to change the Batteries as required.

